

## Lesson 03

### Methods of Generating Electricity Direct and Alternating Voltage & Current Primary and Secondary Cells

#### Methods of Generating Electricity

**1. Chemical Methods** As we said in Lessons 1 and 2, electricity was first generated by humans using chemistry by Galvani and Volta back in the late 1700s. It was done first by Galvani with dissimilar metals and later by Volta with his "electrical pile" of cells in series (battery).

In general, electricity generated by chemical methods is ***DIRECT CURRENT (DC)*** and we will have to use an electronic circuit if we wish to convert our DC to AC (Alternating Current).

There are a HUGE number of metals and chemicals we can mix together to produce electricity (not an infinite number, but close). One of the classic "science fair" experiments is to take house electrical wire, some aluminum foil and immerse them in a potato (phosphoric acid) or lemon (citric acid). There is just enough acid in the vegetable or fruit to act as the ***ELECTROLYTE*** (carrier of current) between the dissimilar metals. At the aluminum end, the aluminum is eaten away into the acid solution, giving up two electrons for each aluminum atom dissolved. At the penny (copper) end, the two electrons and the copper form hydrogen gas from the hydrogen in the electrolyte. If a circuit (like a light bulb) were to be connected between the copper and the aluminum, the excess electrons would flow FROM the aluminum to the copper.

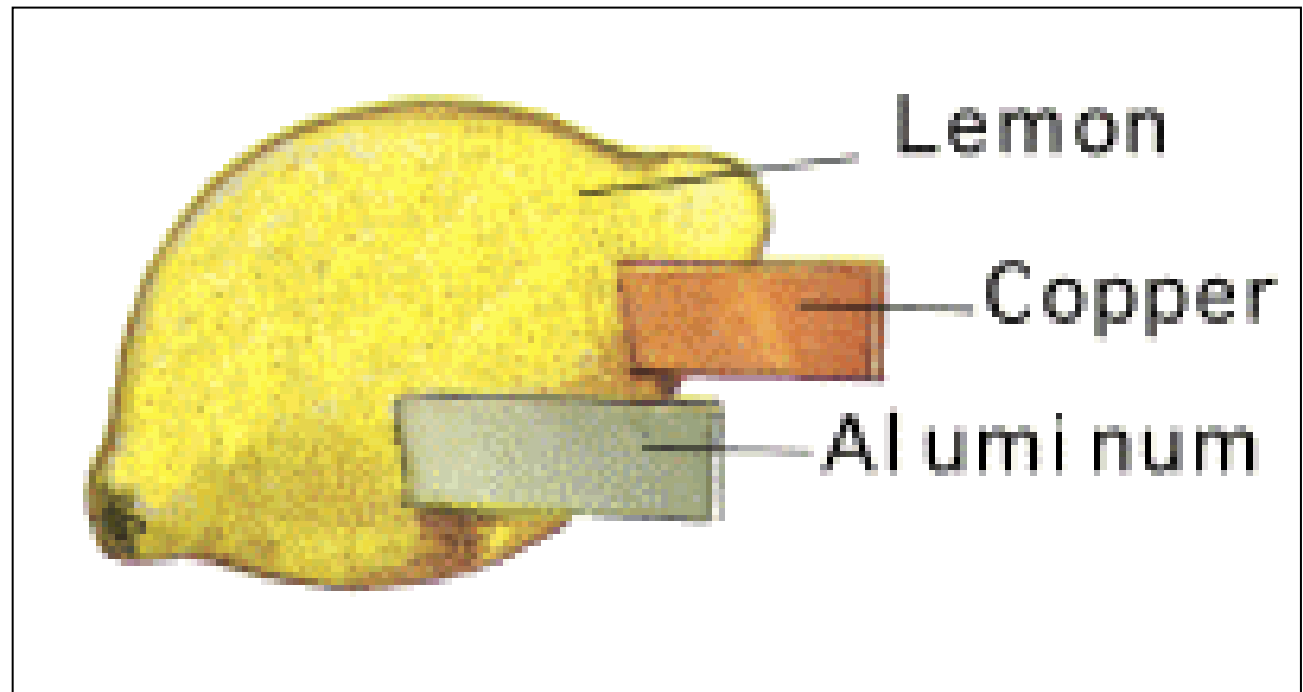

Unfortunately for most light bulbs, there would not be enough voltage and current that you could see any light at all, even though there was some small current. We would need HUNDREDS of lemons or potatoes, pennies, and pieces of aluminum to cause the most feeble of lights from the smallest incandescent household bulb. (See <http://latteier.com/potato/> for some interesting uses of hundreds of pounds of potatoes.)

Here we see several lemon **CELLS** connected in **SERIES** to form a **BATTERY**. Strictly speaking, a **CELL** is comprised of two metal plates and an electrolyte. When we put these cells in **SERIES** to increase the **VOLTAGE** or in **PARALLEL** to increase the **CURRENT** we have a **BATTERY**.

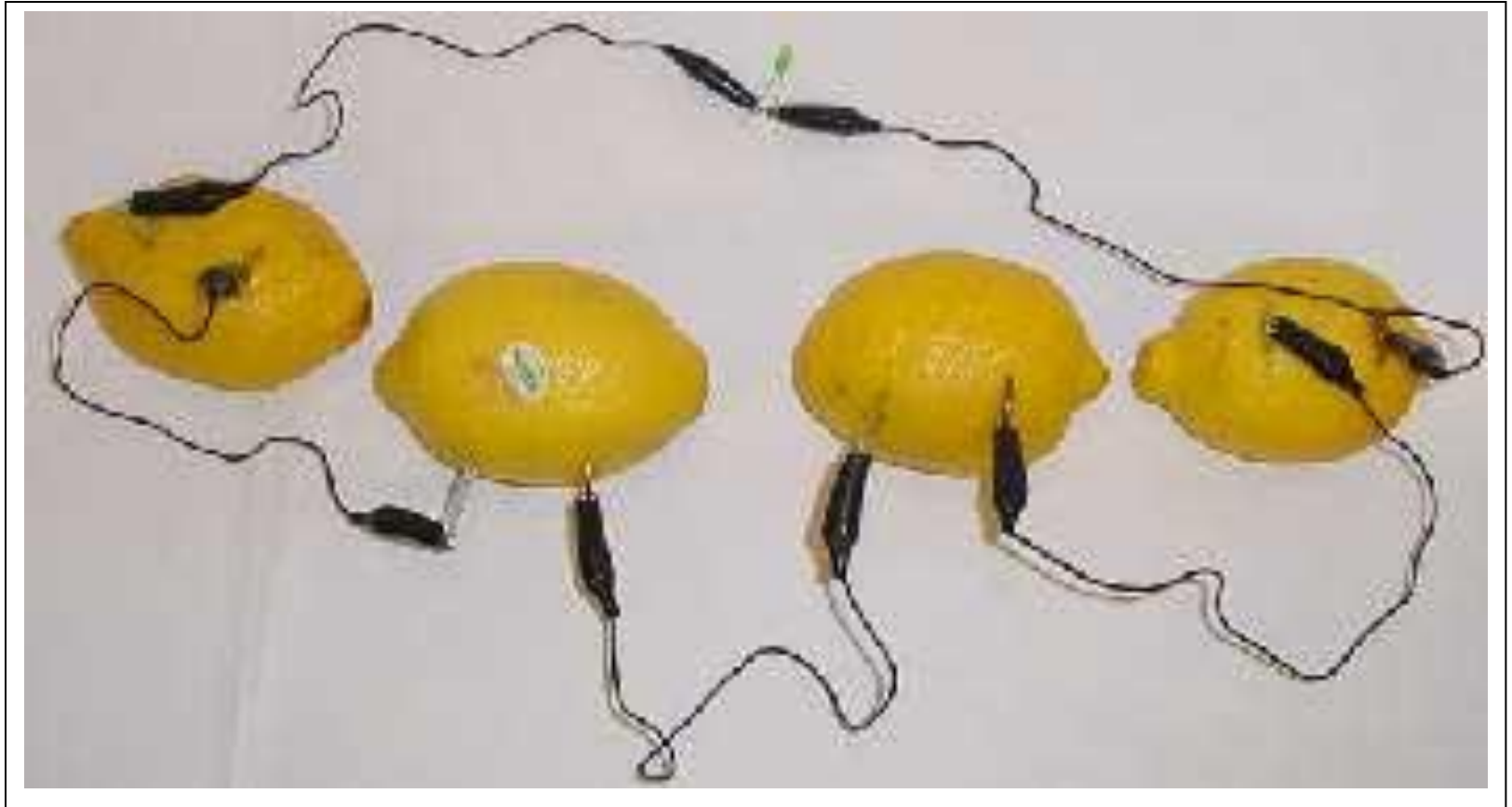

Fortunately, we have our choice of metals and electrolytes. In particular, copper and zinc are good metals to use (fairly high voltage and easy to come by), any citrus juice, vinegar (acetic acid), or a potato will work just fine. Copper can be obtained from copper wire (household romex cable, copper hookup wire, etc.), zinc can be obtained from any "galvanized" (zinc plated) metal such as galvanized steel, galvanized nails, etc.

However, each of these batteries has one thing in common. Both the negative electrode (aluminum or zinc) is slowly eaten away and the hydrogen from the acid electrolyte is slowly diluted by the liberation of hydrogen from the positive electrode. We cannot pass electricity back through our cell and regain its use...once it is gone, it is gone. We call non-rechargeable cells **PRIMARY CELLS**.

Typical **PRIMARY CELLS** are carbon-zinc and alkaline flashlight batteries and small watch batteries made from silver, mercury, zinc, and lithium.

One problem that you are probably aware of with carbon-zinc cells is that the outer "sleeve" of the cell is the zinc anode and is "eaten away" as the battery is used. Unless some sort of outer impervious jacket is used around the zinc, as holes are eaten in the zinc the ammonium and zinc chloride paste will leak out and ruin the flashlight, toy, or radio that the battery is used in.

Alkaline cells (so called because the ammonium chloride acid is replaced with potassium hydroxide alkali) does not react so strongly with the zinc and therefore is much less likely to leak. Not impossible, just less likely.

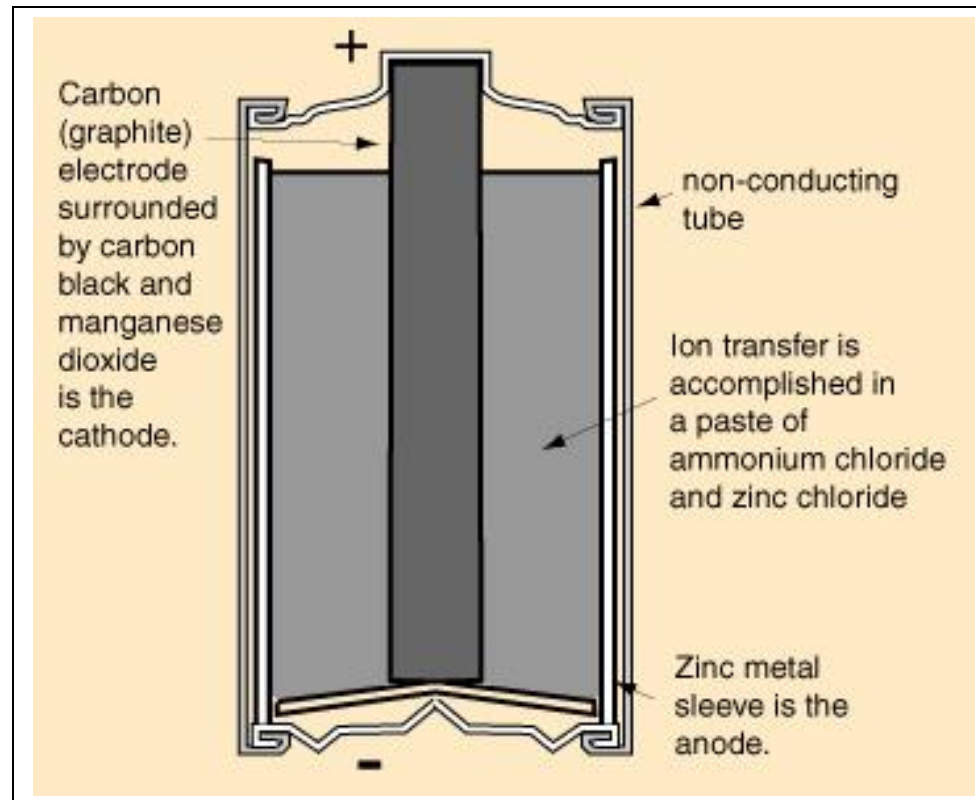

Another cell chemistry is lead, lead dioxide, and sulphuric acid. In this reaction, the lead plate has the excess electrons (negative plate) and the lead dioxide has the deficiency of electrons (positive plate).

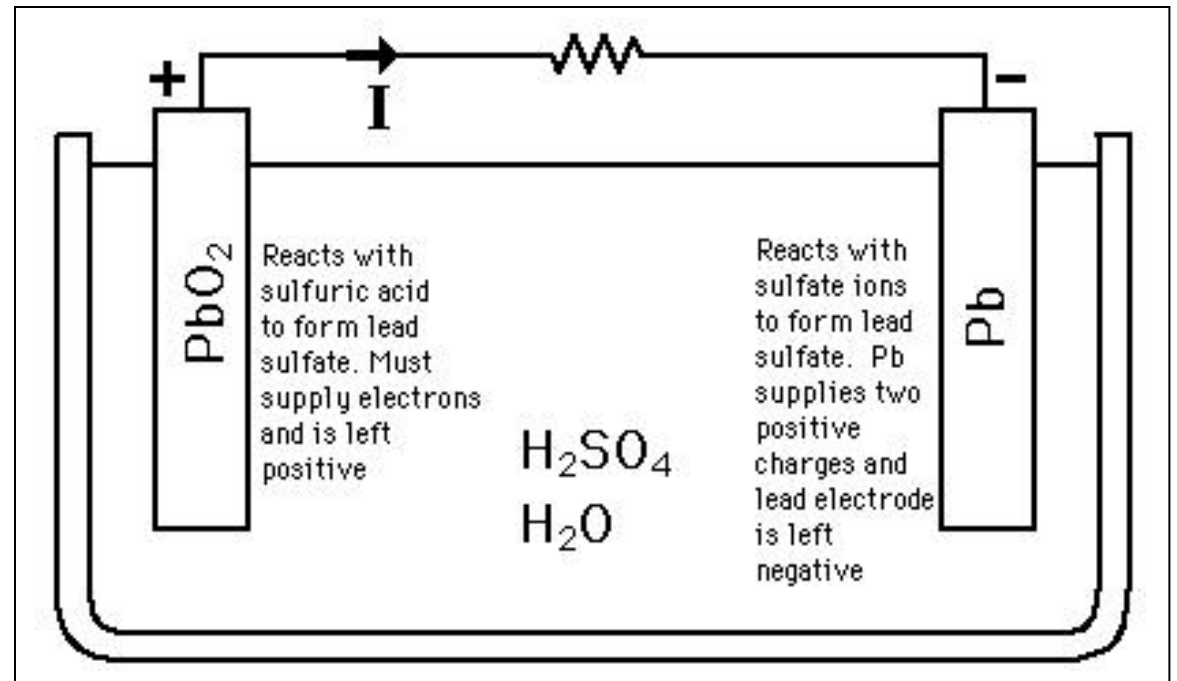

However, this particular chemistry is **REVERSABLE**. That is, you can draw current from the battery to power your circuit, but if you run electricity back in the reverse direction you can recharge the battery. We call these types of rechargeable batteries **SECONDARY CELLS**. The battery in your automobile is this lead-acid type of battery. You can use the battery to power a motor to start the car. Once started, your alternator runs current back through the battery to recharge it.

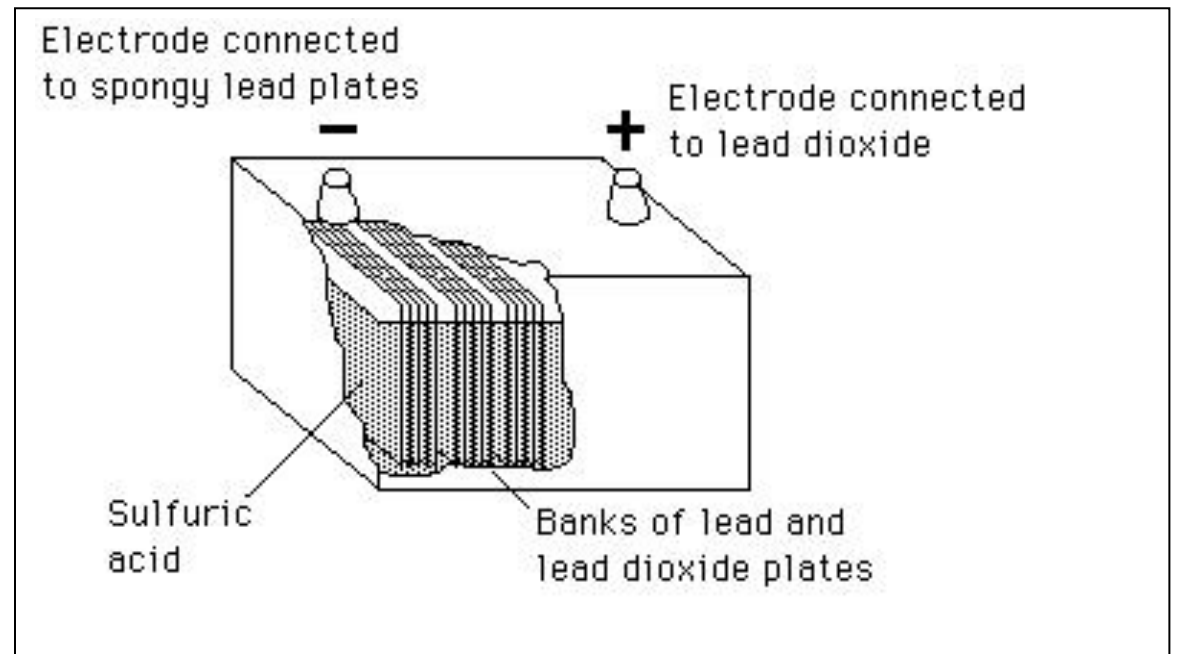

**CELLS & BATTERIES**  
**Chemical Generators of Electrical Energy**

**Important Characteristics**

Battery Type	Energy Density (Watt-Hours per Kilogram)	Cell Voltage	Discharge Slope	Shelf Life for 80% of initial charge	Relative Cost	Typical applications
--------------	--	--------------	-----------------	---	---------------	-------------------------

**Primary Cells**

Carbon-Zinc	85	1.5	Steep	2 years	Inexpensive	Flashlights, toys
Alkaline	125	1.5	Almost flat	5 years	Moderate	General electrical & electronic
Silver Oxide	120	1.6	Flat	3 years	Expensive	Watches, Hearing Aids
Zinc-Air	340	1.5	Flat	10 years (unactivated)	Expensive	Hearing Aids
Lithium	230	3.0	Flat	7 years	Moderate	Computer memory, Cameras

**Secondary Cells**

Lead-Acid	35	2.0	Moderate	6 months	Inexpensive	Automobiles, UPS
Nickel-Cadmium ("Nicad")	45	1.3	Almost Flat	3 months	Moderate	Tools, radios, general electronics
Nickel Metal Hydride ("NiMH")	60	1.3	Flat	2 months	Moderate	Laptops, Digital Cameras
Lithium Ion ("LiON")	90	4.0	Flat	2 years	Moderate	Digital cameras, cell phones

Note that batteries are generally rated for capacity by AMPERE-HOURS, or more colloquially amp-hours. This is the amount of current that the battery can put out over time. Let's take a small automobile battery rated at 35 amp-hours. This means that you can draw 35 amperes of current for an hour. Or, you can draw 18 amps for two hours, 9 amps for four hours, and so on. Small flashlight and radio batteries are generally rated in milliampere-hours, or mAh. For example, a standard alkaline 9 volt "transistor radio" battery is rated somewhere around 400 mAh, which means that your radio, drawing somewhere around 30 mA to operate, will operate normally for about  $(400/30)$  13 hours before the battery is spent.

Another chemical way of producing electricity is by a FUEL CELL. A fuel cell takes hydrogen (or a hydrocarbon fuel such as methanol, kerosene, or gasoline) and chemically "burns" it to form water and electricity. Since the byproduct of the cleanest fuel cells simply takes oxygen from the air and hydrogen gas to form water plus electricity, it is one of the cleanest methods we have of producing electricity.

Here are a lot of websites where you can get more information on cells and batteries than you could ever want (be careful on the "sulfate busters" pages about their claims):

[www.powerstream.com/batteryfaq.html](http://www.powerstream.com/batteryfaq.html)

[www.irdusa.com/batterymax/](http://www.irdusa.com/batterymax/)

<http://www.europulse.com/eng/technology/index.shtml>

<http://www.enersysreservepower.com/applicationsInfo.asp?appID=16>

[www.howstuffworks.com/battery.htm](http://www.howstuffworks.com/battery.htm)

Even some quasi-reliable sources have experimented with sulfate busters:

<http://www.rstengineering.com/kitplanes/KP0204/KP0204.htm>



**2. Electromagnetic Electrical Generation.** The principle behind any electromagnetic generation of electricity is that (as Hans Oersted showed us in 1800 and Faraday demonstrated in 1820) any motion of a magnet around a wire will produce electricity. Not to steal the thunder from Lesson 5, but ANY method of moving either magnet or wire will result in the generation of electricity.

It is here that we note first that electromagnetic generation of electricity by moving magnets or coils of wire will produce **ALTERNATING CURRENT** and we will have to use electronic circuits to produce **DIRECT CURRENT**.

How can we move either coils or magnets?

- a. Connect one or the other to a rotating motor. Example - connecting an alternator by a belt to the crankshaft of an internal combustion engine to produce electricity to recharge a battery (after converting the AC of the alternator to the DC required by the battery).
- b. Connect one or the other to a rotating source of energy such as a steam engine turbine (powered by coal, oil, or other hydrocarbon source or a nuclear/thermonuclear heat source) or a waterwheel powered by water falling through some distance. The first method (powered by hydrocarbons) is called a "fossil fuel" generator or "nuclear" power plant and the second method is called hydroelectric generation. Most domestic and industrial energy is produced by one of these methods. Here is a picture of a large steam turbine. Note the size of the turbine compared to the (blue jacket) workers.
- c. Use wind, geothermal ("volcano fissure") or wave power to spin a turbine attached to either a coil or a magnet.
- d. Use the HEAT ENERGY delivered by the sun to boil water for a steam turbine.





### 3. Photovoltaic Generators

Without going too deeply into the photon theory of light and the photoelectric effect (google "photoelectric effect" and "Einstein" or "Nobel prize", physics, and 1921) let me simply state that light, which is comprised of photons, can knock an electron out of its outer orbit in many substances. Thus, sunlight hitting a crystal of silicon can knock an electron out of its outer orbit. If we have  $6.24 \times 10^{18}$  photons knocking electrons out of orbit every second, according to Coulomb and Ampere, we have one ampere of current that can possibly flow.

Silicon is not the only material that we can make a "solar cell" out of, but it is by far the cheapest at this point in time. The raw material for pure silicon is silicon dioxide which you probably know as common sand.

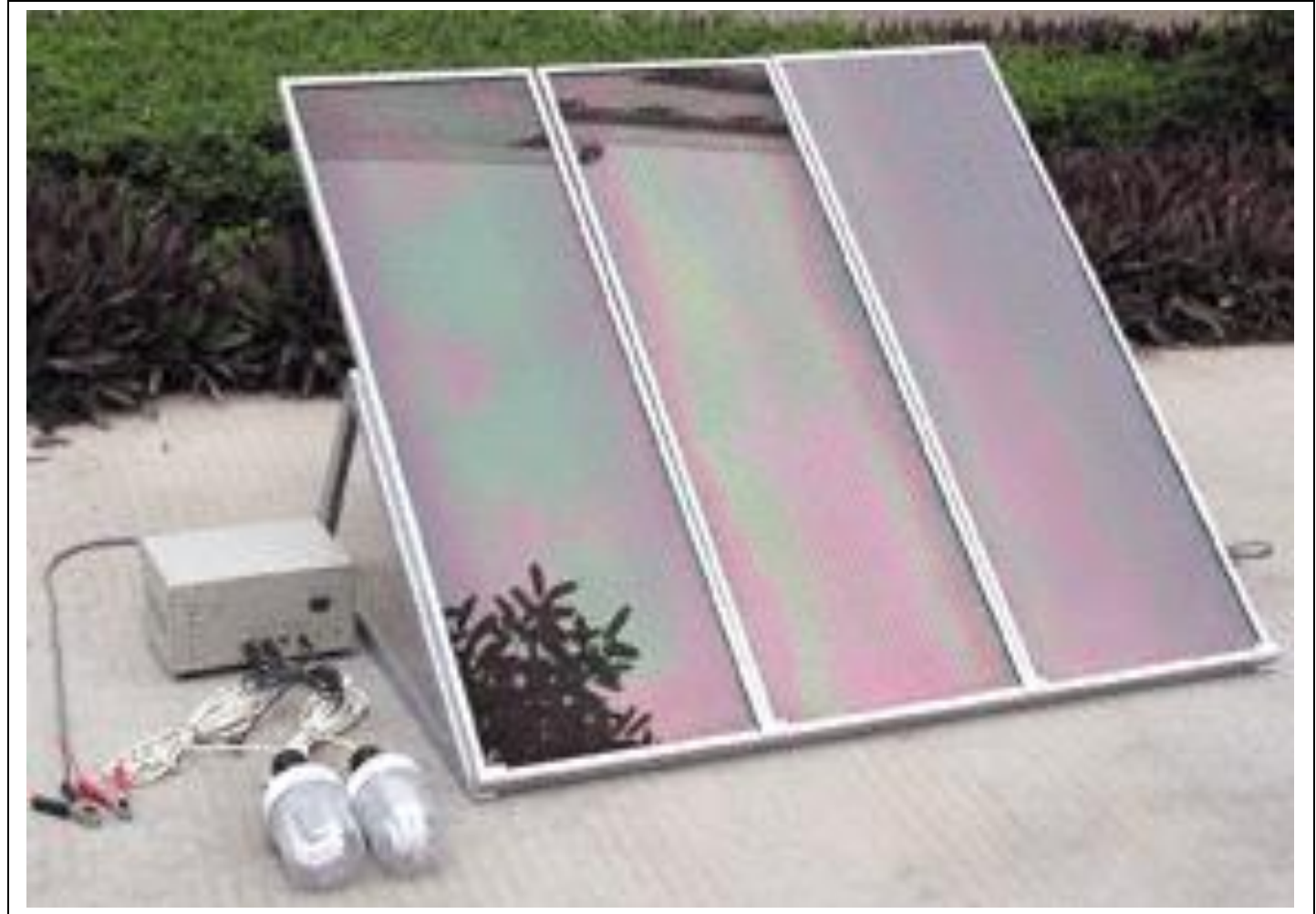

However, solar cells, while relatively cheap, still can't compete economically with "on the grid" commercially generated power described in (2.) above. Let's take a practical example:

- a. The solar cells shown here are from Harbor Freight and sell for \$199 (on sale from \$299). The batteries that you would need to store the electricity for night are perhaps another \$100. Say, by the time you buy controllers, inverters, and the like that you have

\$500 invested in your "system". The system is rated at 45 watts (full summer sun) so figure an average of 30 watts during daytime over the span of a year. A kilowatt-hour generated at 30 watts per hour takes 33 hours.

b. That same kilowatt-hour generated at a steam turbine plant, delivered to you, costs approximately twenty cents. Thus, to generate the \$500 worth of energy costs that your system cost you, you would have to burn 2500 kilowatt-hours of electricity.

c. To generate 2500 kilowatt-hours of solar energy, you would have to have generated 82,000 hours of solar electricity. But wait, that assumed a 12 hour daylight "day". For a real day, we would have to generate that power for 155,000 hours in a 24 hour day. Now dividing 155,000 by 24, we come up with the time to generate that power as 6875 days, or a little less than 16 years to "break even" on our investment. Oops. Not to mention that solar cells do have a finite life and so do storage batteries.

d. On the other hand, reducing the wasted electrical energy in the average home (yes, I do leave my 450 watt computer supply running 24/7), and noting that there are some remote sites that to bring in power is prohibitively expensive -- not to mention the long extension cord to power an orbiting satellite -- mean that there is a break-even point for solar power that may in some instances be less expensive than the local electric power company. You will also note that the cost of using fossil fuels to generate electricity has not gone down in forever.

e. Don't forget, you will only get 30 watts from this system, and if you use it all during the day you won't have anything left over for the night. It takes a pretty hefty investment in solar cells to be totally free from the grid.

**4. Mechanical (Piezoelectric) Generation** Certain crystalline substances (Quartz, Rochelle Salts, etc.) have the capability of generating electricity when struck with a mechanical object. The best example of a piezoelectric generator is the spark igniter on a backyard barbecue. When a spring-loaded hammer hits a crystal, it generates up to 15 kilovolts of spark, enough to jump a gap of about half an inch -- certainly sufficient to ignite propane vapor. For an interesting application of the igniter, go to this website: <http://www.swanstrom.net/petes/shoot/spudgun/index.htm>

One interesting phenomenon of piezoelectricity is that the process is reversible. That is, if you put a voltage across a crystal it will "ring" with a precise frequency while deforming. We will make use of this effect when we try to make a precision timer for a clock.



**5. Thermocouple Generation** Any two dissimilar metal wires, when twisted together and heated will produce a voltage. However, this voltage can only be measured with metal probes, which themselves will form a thermocouple which makes using thermocouples to generate electricity relatively impractical. However, as a method of measuring hot temperatures (say, an internal combustion exhaust gas temperature of 1200°F or so) they are quite accurate. While ANY two metals COULD be used, there are half a dozen combinations (chromel-alumel, platinum-rhodium, etc.) that have come to be the standard for temperature measurement.

